



Gallium Nitride 50V, 280W, 3.6-4.0GHz RF Power Transistor

Description

The STBV40280BY4V is a 280-watt, internally matched GaN HEMT, designed for 5G cellular applications with frequencies from 3.6-4.0GHz, **enabled by wide band VBW capability to support IBW \geq 200MHz.**

It can be configured as asymmetrical Doherty for 4G or 5G application, delivering 40W average power, according to normal 8.5dB back off.

There is no guarantee of performance when this part is used in applications designed Outside of these frequencies.

- Typical **3.7-4GHz** Doherty Pulsed CW and 1C W--CDMA Characterization Performance:

$V_{DD} = 50$ Vdc, $I_{DQA} = 130$ mA, $V_{GSB} = -5.6$ Vdc,

(1) Pulsed condition: 20us and 10%, $P_{sat} = P5dB$

(2) 1C WCDMA; Signal PAR = 10 dB @ 0.01% Probability on CCDF.

STBV40280BY4V

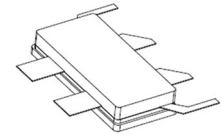

Freq (GHz)	Pulse CW Signal ⁽¹⁾				$P_{avg} = 46.0$ dBm WCDMA Signal ⁽²⁾		
	P3 (dBm)	P3 (W)	P5 (dBm)	P5 (W)	Gp (dB)	η_D (%)	ACPR _{5M} (dBc)
3.7	54.01	250	54.50	281	12.03	44.61	-29.78
3.8	54.71	296	55.10	323	12.84	45.60	-35.31
3.9	54.18	261	55.00	316	12.55	45.56	-36.18
4.0	53.25	210	54.56	286	12.16	44.25	-33.34

Applications

- Asymmetrical Doherty amplifier within N77 5G band and S band power amplifier

Important Note: Proper Biasing Sequence for GaN HEMT Transistors

Turning the device ON

1. Set VGS to the pinch-off (VP) voltage, typically -5 V
2. Turn on VDS to nominal supply voltage
3. Increase VGS until IDS current is attained
4. Apply RF input power to desired level

Turning the device OFF

1. Turn RF power off
2. Reduce VGS down to VP, typically -5 V
3. Reduce VDS down to 0 V
4. Turn off VGS

Figure 1: Pin Connection definition

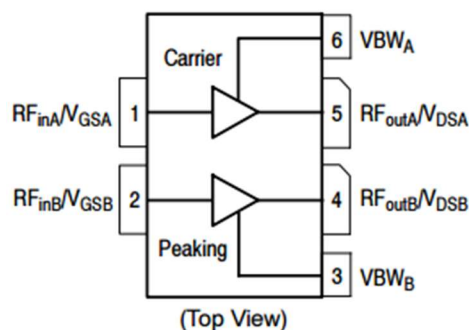



Table 1. Maximum Ratings

Rating	Symbol	Value	Unit
Drain—Source Voltage	V_{DSS}	+200	Vdc
Gate—Source Voltage	V_{GS}	-8 to +0.5	Vdc
Operating Voltage	V_{DD}	55	Vdc
Maximum gate current	I_{gs}	40.2	mA
Storage Temperature Range	T_{stg}	-65 to +150	°C
Case Operating Temperature	T_c	+150	°C
Operating Junction Temperature	T_J	+225	°C

Table 2. Thermal Characteristics

Characteristic	Symbol	Value	Unit
Thermal Resistance, Junction to Case by FEA $T_c=85^\circ\text{C}$, $P_{out}=40\text{W}$, 3.9GHz Doherty application board	$R_{\theta JC}$	2.1	°C /W

Table 3. Electrical Characteristics (TA = 25°C unless otherwise noted)

DC Characteristics (main path, measured on wafer prior to packaging)

Characteristic	Conditions	Symbol	Min	Typ	Max	Unit
Drain-Source Breakdown Voltage	$V_{GS}=-8\text{V}$; $I_{DS}=15\text{mA}$	V_{DSS}		200		V
Gate Threshold Voltage	$V_{DS}=10\text{V}$, $I_D=15\text{mA}$	$V_{GS(th)}$	-4		-2	V
Gate Quiescent Voltage	$V_{DS}=50\text{V}$, $I_{DS}=130\text{mA}$, Measured in Functional Test	$V_{GS(Q)}$		-3.15		V

DC Characteristics (peak path, measured on wafer prior to packaging)

Characteristic	Conditions	Symbol	Min	Typ	Max	Unit
Drain-Source Breakdown Voltage	$V_{GS}=-8\text{V}$; $I_{DS}=25.2\text{mA}$	V_{DSS}		200		V
Gate Threshold Voltage	$V_{DS}=10\text{V}$, $I_D=25.2\text{mA}$	$V_{GS(th)}$	-4		-2	V
Gate Quiescent Voltage	$V_{DS}=50\text{V}$, $I_{DS}=200\text{mA}$, Measured in Functional Test	$V_{GS(Q)}$		-3.15		V

Ruggedness Characteristics

Characteristic	Conditions	Symbol	Min	Typ	Max	Unit
Load mismatch capability	3.9GHz, $P_{out}=40\text{W}$ WCDMA 1 Carrier in Doherty circuit All phase, No device damages	VSWR		10:1		



3.7-4.0GHz

Figure 3: Efficiency and power gain as function of Pout

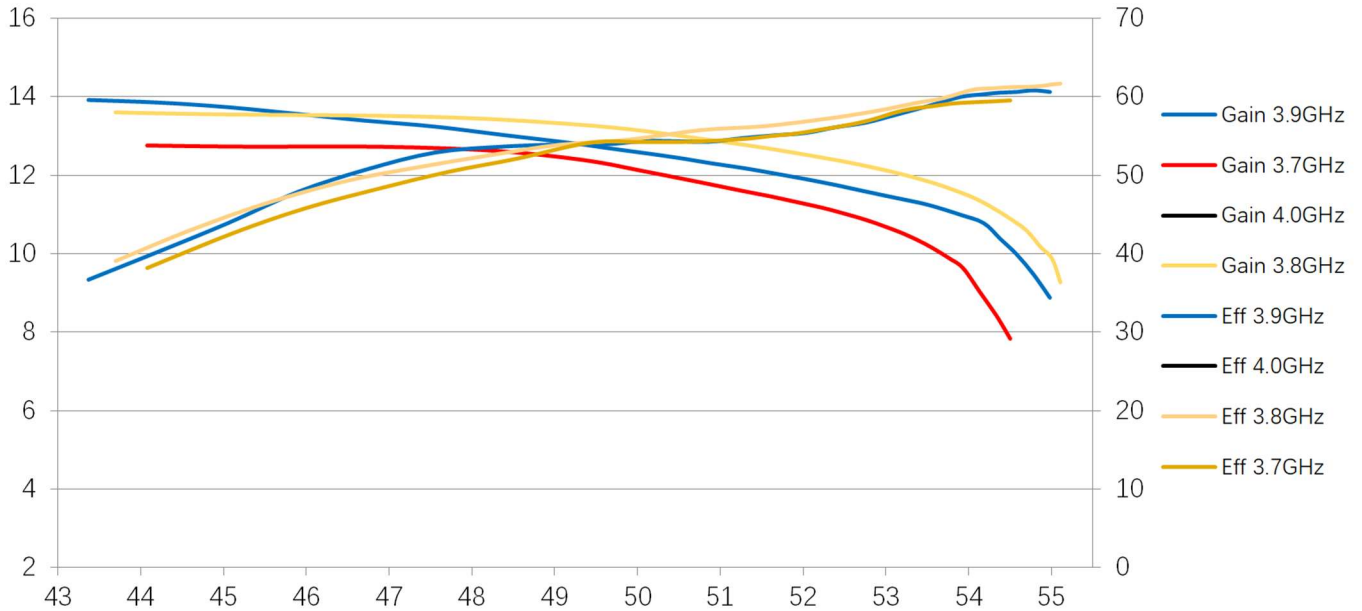

Figure 4: Network analyzer output, S11 and S21

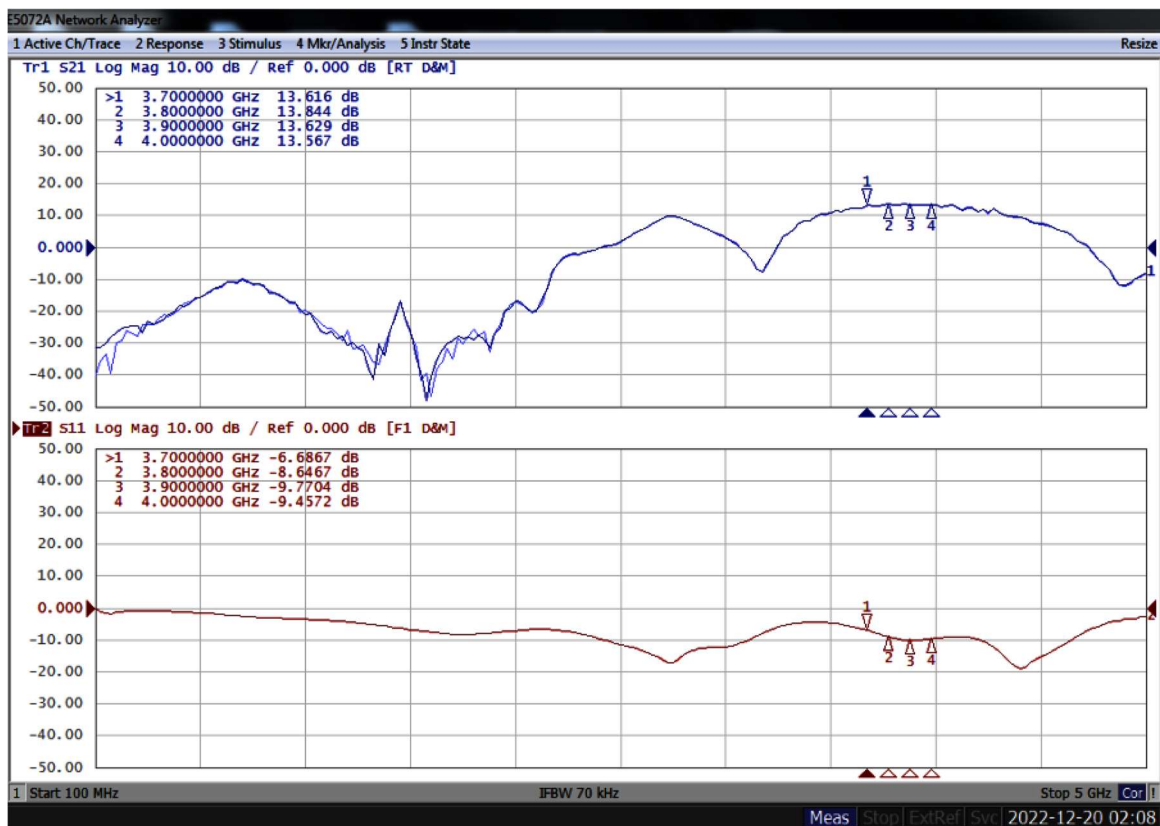

Figure 5: Picture of application board Doherty circuit for 3.7-4GHz

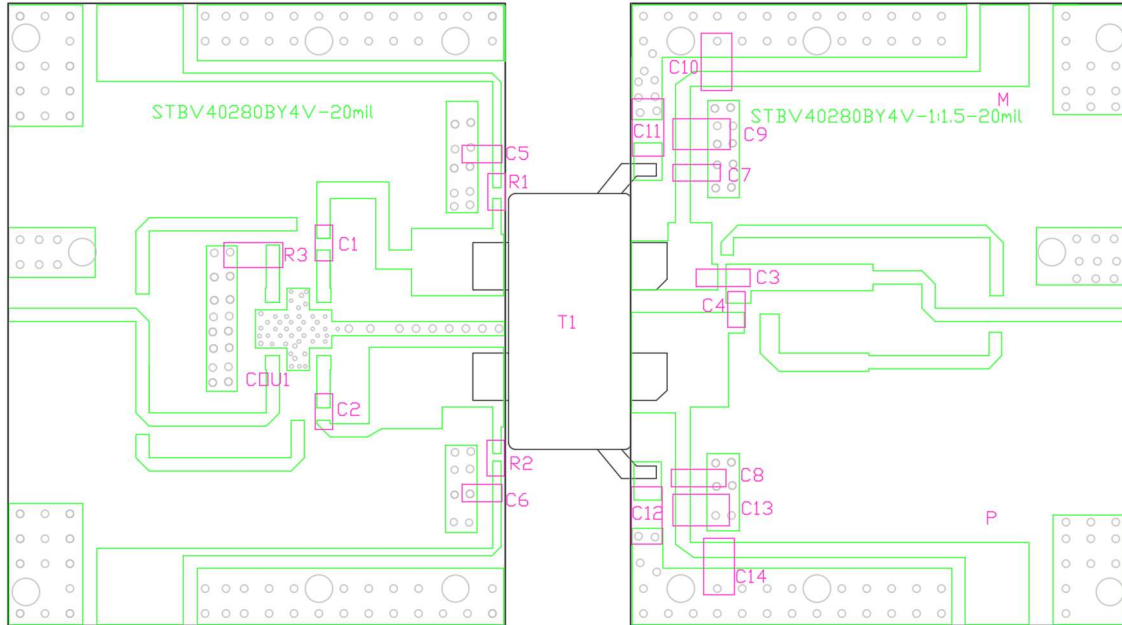
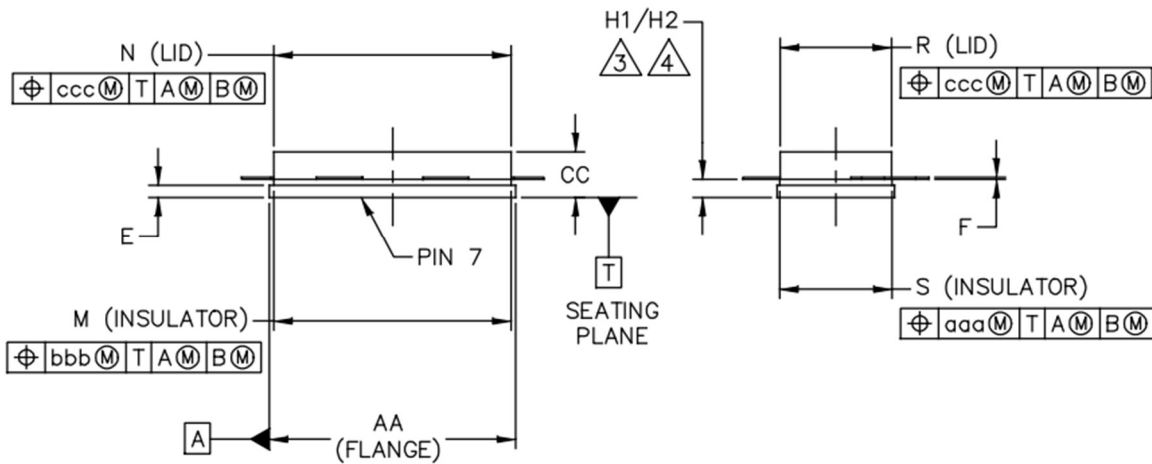
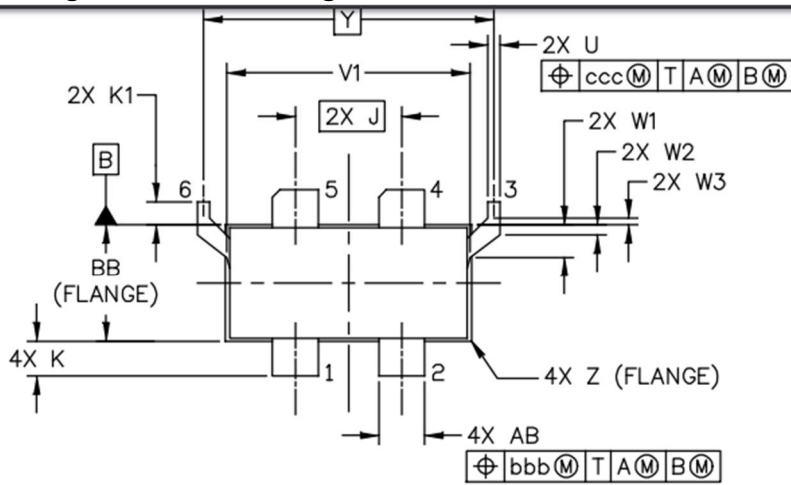

Table 4. Bill of materials of application board (PCB layout upon request, RO4350B 20mils)

Part	Quantity	Description	Part Number	Manufacture
C1,C2,C6, C7,C8,C5	7	8.2pF High Q Capacitor	251SHS8R2BSE	TEMEX
C3	1	1.1pF High Q Capacitor	ATC600S1R1	ATC
C4	1	2.0pF High Q Capacitor	251SHS2R0BSE	TEMEX
C10,C11,C12,C9 C8,C13,C14	6	10uF MLCC	GRM32EC72A106M E05	Murata
R1,R2	2	10 Ω Power Resistor	ESR03EZPF10R0	ROHM
R3	1	51 Ω Power Resistor	S1206N	RN2
COU1	1	3 dB Bridge	XC3500P-03S	ANAREN
T1	1	280W GaN Dual Transistor	STBV40280BY4V	Innegration



Earless Flanged Ceramic Package; 6 leads- BY4V



DIM	INCH		MILLIMETER		DIM	INCH		MILLIMETER	
	MIN	MAX	MIN	MAX		MIN	MAX	MIN	MAX
AA	.805	.815	20.45	20.70	R	.365	.375	9.27	9.53
BB	.380	.390	9.65	9.91	S	.365	.375	9.27	9.53
CC	.125	.170	3.18	4.32	U	.035	.045	0.89	1.14
E	.035	.045	0.89	1.14	V1	.795	.805	20.19	20.45
F	.004	.007	0.10	0.18	W1	.0975	.1175	2.48	2.98
H1	.057	.067	1.45	1.70	W2	.0225	.0425	0.57	1.08
H2	.054	.070	1.37	1.78	W3	.0125	.0325	0.32	0.83
J	.350 BSC		8.89 BSC		Y	.956 BSC		24.28 BSC	
K	.0995	.1295	2.53	3.29	Z	R.000	R.040	R0.00	R1.02
K1	.070	.090	1.78	2.29	AB	.145	.155	3.68	3.94
M	.774	.786	19.66	19.96	aaa	.005		0.13	
N	.772	.788	19.61	20.02	bbb	.010		0.25	
					ccc	.015		0.38	



Revision history

Table 4. Document revision history

Date	Revision	Datasheet Status
2022/12/20	V1.0	Preliminary Datasheet Creation

Application data based on LWH-22-23

Notice

Specifications are subject to change without notice. Innogrations believes the information within the data sheet to be reliable. Innogrations makes no warranty, representation or guarantee regarding the suitability of its products for any particular purpose.

“Typical” parameter is the average values expected by Innogrations in quantities and are provided for information purposes only. It can and do vary in different applications and related performance can vary over time. All parameters should be validated by customer’s technical experts for each application.

Innogrations products are not designed, intended or authorized for use as components in applications intended for surgical implant into the body or to support or sustain life, in applications in which the failure of the Innogrations product could result in personal injury or death or in applications for planning, construction, maintenance or direct operation of a nuclear facility.

For any concerns or questions related to terms or conditions, please check with Innogrations and authorized distributors

Copyright © by Innogrations (Suzhou) Co.,Ltd.